

Installation Instructions for the BZE6/V6 and BZG/H Enclosed Switches

ISSUE 2
PK 88173

MOUNTING

- E6 (side mount) and V6 (flange mount): #6 screws (#8 available on certain listings). E6 enclosures meet NEMA 1; V6 enclosures meet NEMA 1 and 3*.
 - BZG/H; #10 screws. Enclosures meet NEMA 1, 3*, 4*, 13*.
 - Side and bottom mounting available. Side mount from either side.
1. Mount switches on flat, rigid surface.
 2. **Sealed, side mounted:** Use sealing washers under screw heads on one side; between switch and mounting surface on other side.
 3. **Unsealed, side mounted:** Use lockwashers under screw heads on one side; under nut on other side.
 4. Connect conduit to complete seal.

*Except Q plungers.

REPLACEMENT PARTS

Basic switch: order according to catalog listing on basic switch being replaced. Replacement packet includes basic switch, mounting hardware, seal boot and bands where required.

Actuators or Accessories

Part	Listing
N2 actuator (roller lever)	6PA2
Q2 actuator (roller lever)	6PA1
N28 actuator (one-way roller lever)	6PA16
Q28 actuator (one-way roller lever)	6PA41
N62 Actuators (rod lever)	6PA140-E6
Q62 Actuators (rod lever)	6PA62
N4 Actuators (manual button)	6PA9
Q4 Actuators (manual button)	6PA7
N18 Actuators (spring)	6PA195
N18 Actuators (spring and bushing)	6PA187-E6
Conduit Seal	2PA1
	2PA6
	2PA16
Seal Boot (black elastomer)	10PA2
Seal Boot (orange silicon)	10PA1
Bottom Cover E6	3PA13-E6
Bottom Cover V6	3PA14-V6
Pilot Light for BZG/H	15LT1

WIRING

Connect grounding screw or lug.

Solderless connections:

1. Use only insulated connectors.
2. Position connectors to provide as much spacing as possible.

NOTICE

1. **Do not** drill or machine housing.
2. **Do not** lubricate any internal part of switch.
3. **Do not** allow internal conduit condensation to drain into switch.
4. **Do not** enlarge mounting holes.

CONDUIT SEALING PACKETS

Packet Listing	Cable O.D. In. (mm)
2PA6	.400 - .435 (10,2 - 11,1)
2PA16	.435 - .470 (11,1 - 12,0)
2PA1	.530 - .570 (13,5 - 14,5)

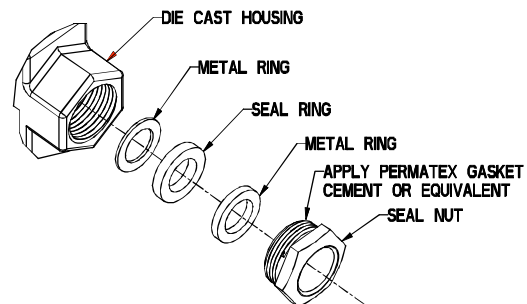

LIQUID TIGHT CONDUIT FITTING

2PA17	.170 - .470 (4,3 - 12,0) 1/2 NPT
-------	----------------------------------

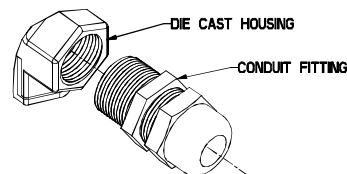

6PA187-E6 ACTUATOR PACKET

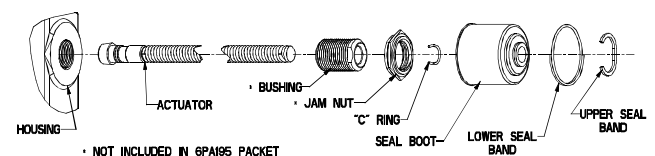

N18 TYPES

If actuator or basic switch is replaced, the actuator may need adjustment to duplicate original switch operating point. To adjust operating point, remove lower seal band from base of seal boot. "Peel back" seal boot to expose bushing. With basic switch **unoperated**, slowly turn bushing clockwise until basic switch operates. **Do not turn further after operating click is heard.** Turn bushing back 1/2 turn. Tighten jam nut on bushing.

ACTUATOR DESCRIPTION

"Q": unsealed. "N": seal boot around plunger. Horizontal and vertical lever adjustment.

- N80 & Q8: Roller plunger actuated.
- N81 & Q81: Cross roller plungers
- N2 & Q2: Roller lever for slide or cam operation.
- N28 & Q28: one-way roller lever actuator.
- N62 & Q62: 6 inch rod actuator.
- N4 & Q4: large button for easy hand operation.
- N18: Coil spring wobble lever.

N2 & Q2, N4 & Q4, N28 & Q28, N62 & Q62 TYPE ACTUATOR ADJUSTMENT

Vertical Adjustment

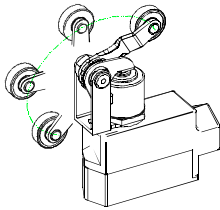

Vertical Adjustment Range

N2 & Q2 - Roller lever	225°	To adjust: loosen hex nut, adjust arm to desired position, tighten hexnut.
N4 & Q4 - Hand op.	180°	
N62 & Q62 - Rod lever	225°	
N28 & Q28 - One way	180°	

Calibration

1. One lever arm serration: 8.18°.
2. One serration of lever arm and fluted washer as a unit: 8°.
3. One serration of lever arm with one serration of fluted washer in opposite direction: 0.18°.

LUBRICATING INSTRUCTIONS for Roller Plunger Switches only (N80, N81, Q8, Q9, Q81)

For maximum life, periodically put a **drop or two** of lightweight oil on the roller. Specific application conditions will determine lubricating frequency.

Horizontal Adjustment

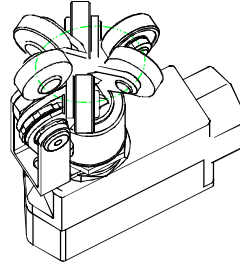

Horizontal Adjustment Range

"Q" types; [8] 45° positions - loosen mounting nut; adjust to new position, seating bracket base pin. Tighten mounting nut.

Sealed "N" types; loosen mounting nut; adjust to any position; tighten mounting nut.

WARRANTY/REMEDY

Honeywell warrants goods of its manufacture as being free of defective materials and faulty workmanship. Commencing with date of shipment, Honeywell's warranty runs for 18 months. If warranted goods are returned to Honeywell during that period of coverage, Honeywell will repair or replace without charge those items it finds defective. The foregoing is Buyer's sole remedy and is **in lieu of all other warranties, expressed or implied, including those of merchantability and fitness for a particular purpose.**

For application assistance, current specifications, pricing or name of the nearest Authorized Distributor, contact a nearby sales office. Or call:

1-800-537-6945 USA

1-416-293-8111 Canada

1-815-235-6847 International

INTERNET

<http://www.honeywell.sensing.com>

info@micro.honeywell.com

Honeywell

Helping You Control Your World

MICRO SWITCH

Honeywell Inc.
11 West Spring Street
Freeport, Illinois 61032



Printed with Soy Ink
on 50% Recycled Paper

